

# MILLENIUM

## 975.2MLE/MSE + i

### DESIGN

The MILLENIUM range of attractive ergonomically-designed rotisseries, boasts a number of innovative features for increased functionality and are an ideal show-piece used throughout the world in hotels, restaurants and deli stores.

The electrical heating elements provide an even distribution of heat throughout the unit with 3 different heat settings - offering you the flexibility to cook as little or as much as you need.

Spits are driven by individual motors rotating at 2 ½ times per minute allowing meat or poultry to constantly baste itself, sealing in natural juices and cooking to perfection.

### FEATURES

- ❑ Energy Efficient
- ❑ Independent motors
- ❑ 2 tempered glass doors
- ❑ Reinforced heating elements
- ❑ Equipped with bottom drip tray with drainage tap
- ❑ Powerful halogen lamp

### FINISHES

Standard model in black enamel. A choice of other colours are available. Choses a colour scheme for Millenium.



With chrome or brass trims.

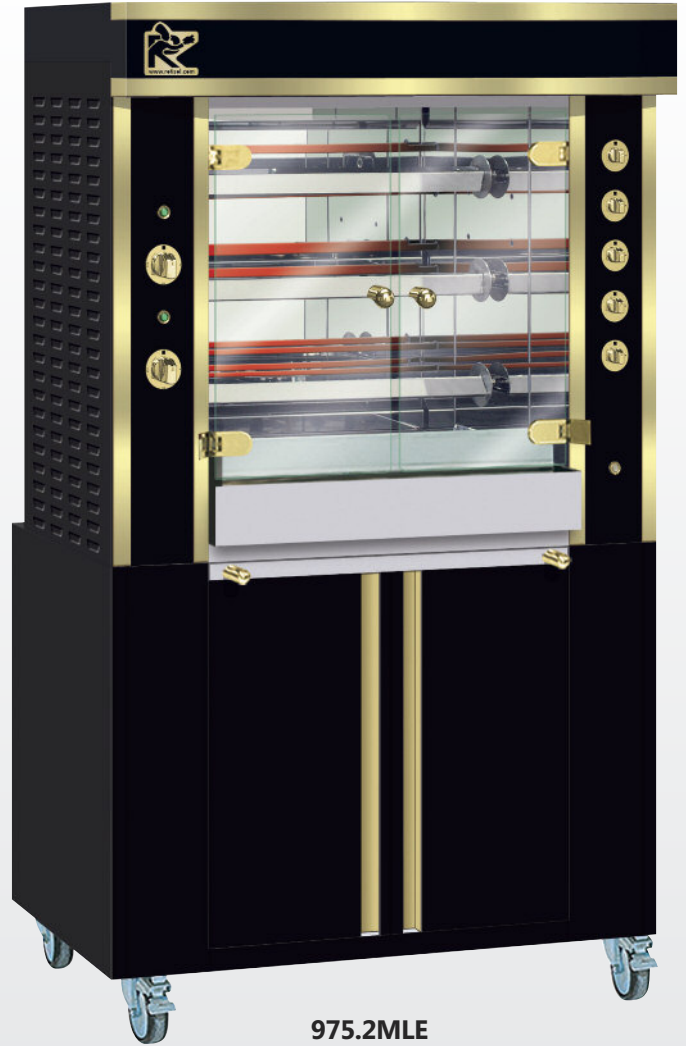
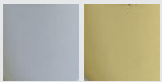









**975.2MLE**

Black and brass finish



### ACCESSORIES

A variety of accessories are available for the unit. Video of available [accessories](#) and video of [vertical spit system](#).

<p><b>CUI975</b> Anti-cutting prongless spit.</p> 	<p><b>BP975</b> Chicken spit.</p> 	<p><b>BRC975</b> Basket spit.</p> 
<p><b>BS975</b> Sabre spit for ham / turkey.</p> 	<p><b>BRRO975</b> Roast-clamp spit.</p> 	<p><b>BA975</b> Lamb/suckling-pig spit. On demand.</p> 
<p><b>GCP975</b> Spare rib rack.</p> 	<p><b>GSV975</b> Raised rack for meat storage.</p> 	<p><b>PID975</b> Stainless steel tray to unspit.</p> 

**Front view**  
Rotisserie with roof (optional)  
and base on casters (optional)

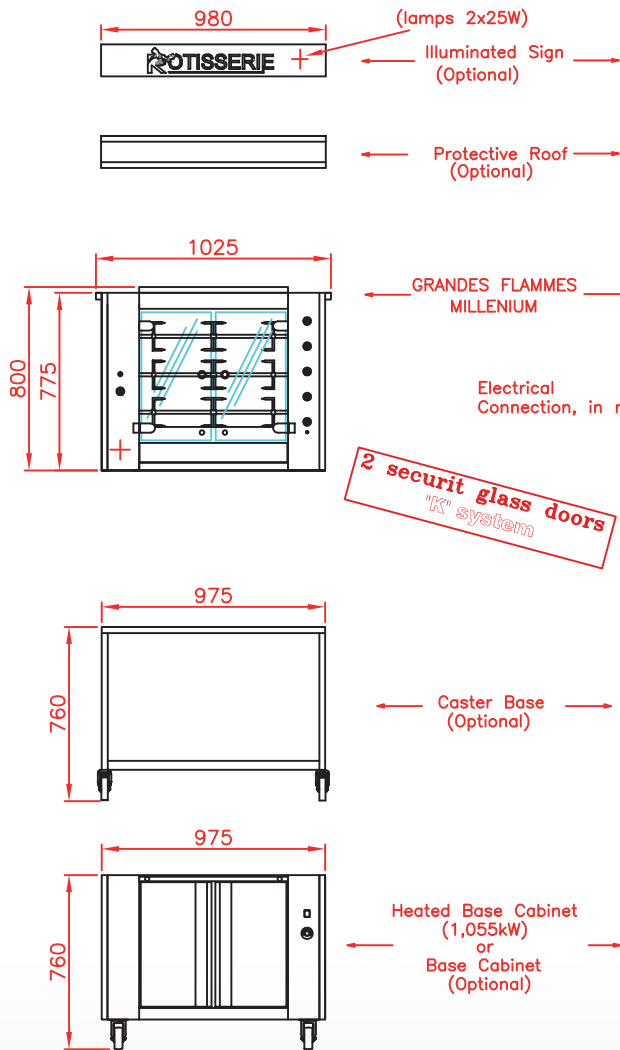

**Side view**  
Rotisserie with roof (optional)  
and base on casters (optional)

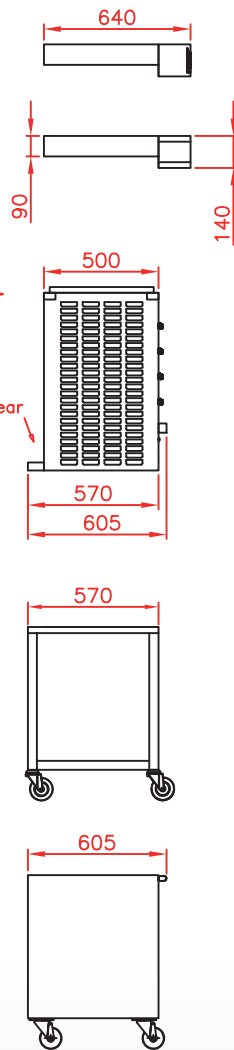

**Top view**  
Rotisserie with roof (optional)  
and base on casters (optional)

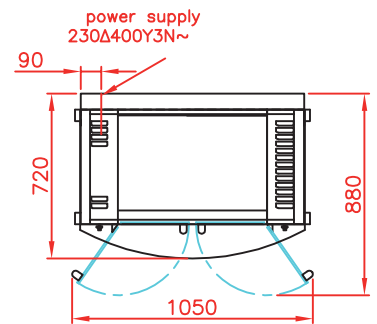

**975.2MSE**  
Stainless steel finish



## SPECIFICATIONS

<b>Electricity</b>	400 V 3 phases + neutral + earth 8.3 kW
<b>Electrical connection</b>	wire length 2 meters
<b>Capacity</b>	4/6 poultries (depending on size)
<b>Warranty</b>	1 year on parts (excluding glass doors)
<b>Extraction</b>	Compulsory
<b>Minimum clearance</b>	5 cm on the left and right, 5 cm at the rear
<b>Weight</b>	55 kg without packing

Revised : June 2014

DISTRIBUTOR / AGENT

### Rotisol S.A.S.

Zone industrielle La Trentaine, Avenue Gustave Eiffel  
77507 Chelles cedex - FRANCE

[bennell@rotisol.com](mailto:bennell@rotisol.com) - Tel : +33 1 64 21 80 00

[www.rotisol.com](http://www.rotisol.com)