

# MILLENNIUM

## 975.5MLG/MSG + i

### DESIGN

The MILLENNIUM range of attractive ergonomically-designed rotisseries, boasts a number of innovative features for increased functionality and are an ideal show-piece used throughout the world in hotels, restaurants and deli stores.

The naked flame from Rotisol's patented burners lick the cast iron hearth creating a spectacular visual, whilst being safe and simple to operate and easy to clean. Spits are driven by individual motors rotating at 2 ½ times per minute allowing meat or poultry to constantly baste itself, sealing in natural juices and cooking to perfection.

### FEATURES

- Energy Efficient
- Independent motors
- 2 tempered glass doors
- Safety with installed thermocouple
- Equipped with bottom drip tray with drainage tap
- Powerful halogen lamp.

### FINISHES

Standard model in black enamel. A choice of other colours are available. Choses a colour scheme for Millenium.



With chrome or brass trims.

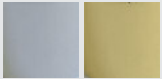









**975.5MLG**

Black and brass finish



### ACCESSORIES

A variety of accessories are available for the unit. Video of available [accessories](#) and video of [vertical spit system](#).

<b>CUI975</b> Anti-cutting prongless spit. 	<b>BP975</b> Chicken spit. 	<b>BRC975</b> Basket spit. 
<b>BS975</b> Sabre spit for ham / turkey. 	<b>BRRO975</b> Roast-clamp spit. 	<b>BA975</b> Lamb/suckling- pig spit. On demand. 
<b>GCP975</b> Spare rib rack. 	<b>GSV975</b> Raised rack for meat storage. 	<b>PID975</b> Stainless steel tray to unspit. 

**Front view**  
Rotisserie with roof (optional)  
and base on casters (optional)

**Side view**  
Rotisserie with roof (optional)  
and base on casters (optional)

**Top view**  
Rotisserie with roof (optional)  
and base on casters (optional)

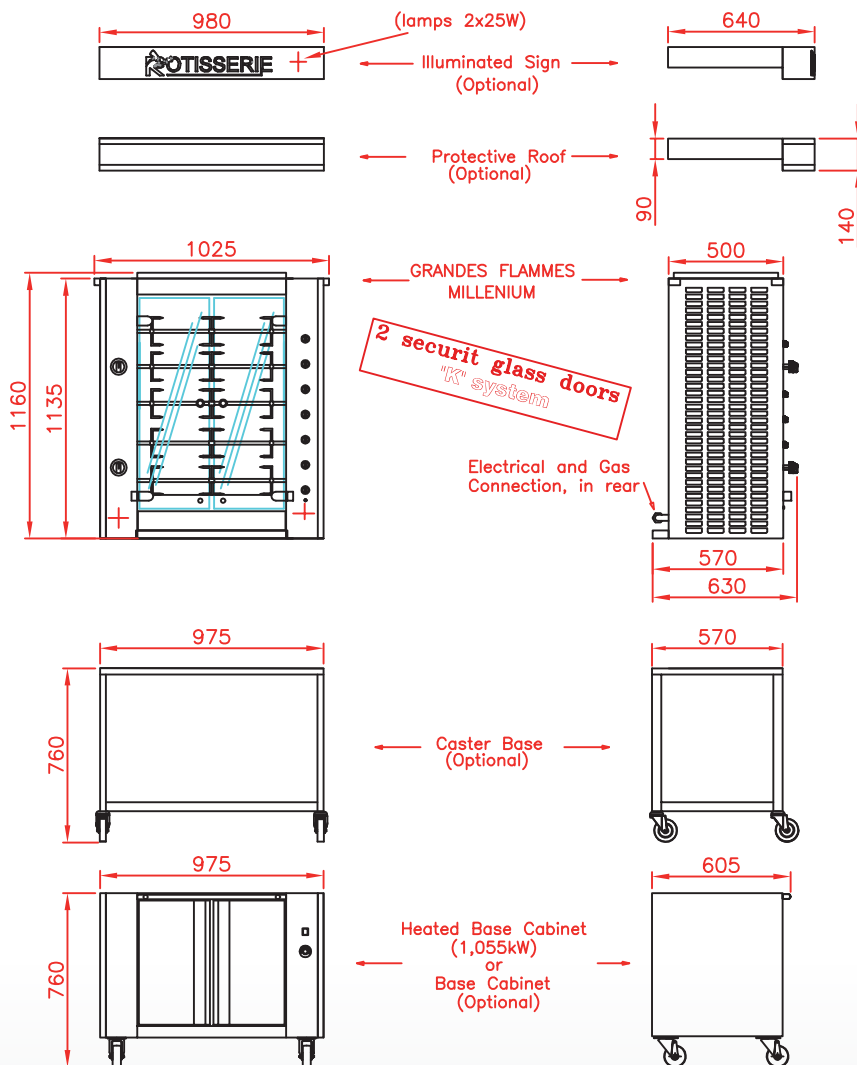

**975.5MSG**

Stainless steel finish



## SPECIFICATIONS

<b>Gas Power</b>	NG 27kW / LPG 21kW
<b>Gas consumption</b>	Natural Gas 97.2 Mj/hr LPG 75.6 Mj/hr
<b>Gas connection</b>	20/27 male
<b>Electricity</b>	230 V 50 Hz + earth 0.4 kW
<b>Capacity</b>	10/15 chickens (depending on size)
<b>Warranty</b>	1 year on parts (excluding glass doors)
<b>Extraction</b>	Compulsory
<b>Minimum clearance</b>	5 cm on the left and right, 5 cm at the rear
<b>Weight</b>	140 kg without packing

Revised : June 2014

AUSTRALIA DISTRIBUTOR

### Rotisol S.A.S.

Zone industrielle La Trentaine, Avenue Gustave Eiffel  
77507 Chelles cedex - FRANCE  
[bennell@rotisol.com](mailto:bennell@rotisol.com) - Tel : +33 1 64 21 80 00  
[www.rotisol.com](http://www.rotisol.com)



PO Box 83 - Oxenford QLD 4210 - AUSTRALIA  
+61 (07) 3218 2111 - [info@creative-commercial.com.au](mailto:info@creative-commercial.com.au)