

MILLENIUM

975.2MLG/MSG + i

DESIGN

The MILLENIUM range of attractive ergonomically-designed rotisseries, boasts a number of innovative features for increased functionality and are an ideal show-piece used throughout the world in hotels, restaurants and deli stores.

The naked flame from Rotisol's patented burners lick the cast iron hearth creating a spectacular visual, whilst being safe and simple to operate and easy to clean. Spits are driven by individual motors rotating at 2 ½ times per minute allowing meat or poultry to constantly baste itself, sealing in natural juices and cooking to perfection.

FEATURES

- Energy Efficient
- Independent motors
- 2 tempered glass doors
- Safety with installed thermocouple
- Equipped with bottom drip tray with drainage tap
- Powerful halogen lamp.

FINISHES

Standard model in black enamel. A choice of other colours are available. Choses a colour scheme for Millenium.



With chrome or brass trims.

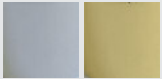









975.2MLG

Black and brass finish



ACCESSORIES

A variety of accessories are available for the unit. Video of available [accessories](#) and video of [vertical spit system](#).

<p>CUI975 Anti-cutting prongless spit.</p> 	<p>BP975 Chicken spit.</p> 	<p>BRC975 Basket spit.</p> 
<p>BS975 Sabre spit for ham / turkey.</p> 	<p>BRRO975 Roast-clamp spit.</p> 	<p>BA975 Lamb/suckling-pig spit. On demand.</p> 
<p>GCP975 Spare rib rack.</p> 	<p>GSV975 Raised rack for meat storage.</p> 	<p>PID975 Stainless steel tray to unspit.</p> 

Front view
Rotisserie with roof (optional)
and base on casters (optional)

Side view
Rotisserie with roof (optional)
and base on casters (optional)

Top view
Rotisserie with roof (optional)
and base on casters (optional)

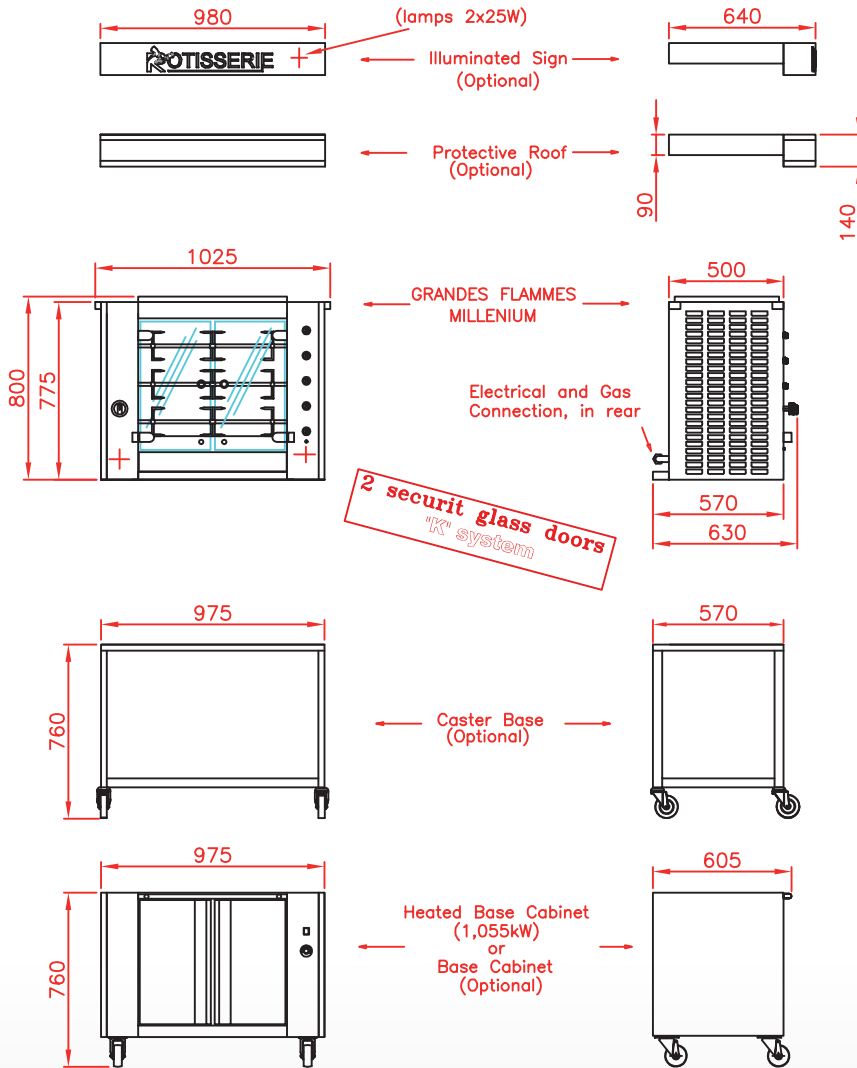

975.2MSG

Stainless steel finish



SPECIFICATIONS

Gas Power	NG 14kW / LPG 11kW
Gas consumption	Natural Gas 48.6 Mj/hr LPG 37.8 Mj/hr
Gas connection	20/27 male
Electricity	230 V 50 Hz + earth 0.34 kW
Capacity	4/6 chickens (depending on size)
Warranty	1 year on parts (excluding glass doors)
Extraction	Compulsory
Minimum clearance	5 cm on the left and right, 5 cm at the rear
Weight	70 kg without packing

Revised : June 2014

AUSTRALIA DISTRIBUTOR

Rotisol S.A.S.

Zone industrielle La Trentaine, Avenue Gustave Eiffel
77507 Chelles cedex - FRANCE

bennell@rotisol.com - Tel : +33 1 64 21 80 00

www.rotisol.com



PO Box 83 - Oxenford QLD 4210 - AUSTRALIA

+61 (07) 3218 2111 - info@creative-commercial.com.au