

MILLENIUM

1375.5MLG/MSG + i

DESIGN

The MILLENIUM range of attractive ergonomically-designed rotisseries, boasts a number of innovative features for increased functionality and are an ideal show-piece used throughout the world in hotels, restaurants and deli stores.

The naked flame from Rotisol's patented burners lick the cast iron hearth creating a spectacular visual, whilst being safe and simple to operate and easy to clean. Spits are driven by individual motors rotating at 2 ½ times per minute allowing meat or poultry to constantly baste itself, sealing in natural juices and cooking to perfection.

FEATURES

- Energy Efficient
- Independent motors
- 2 tempered glass doors
- Safety with installed thermocouple
- Equipped with bottom drip tray with drainage tap
- Powerful halogen lamp.

FINISHES

Standard model in black enamel. A choice of other colours are available. Choses a colour scheme for Millenium.



With chrome or brass trims.

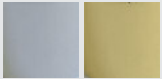









1375.5MLG

Black and brass finish

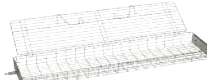

ACCESSORIES

A variety of accessories are available for the unit. Video of available [accessories](#) and video of [vertical spit system](#).

CUI1375 Anti-cutting prongless spit.		BP1375 Chicken spit.		BRC1375 Basket spit.	
BS1375 Sabre spit for ham / turkey.		BRRO1375 Roast-clamp spit.		BA1375 Lamb/suckling- pig spit.	
BCR1375 Spatchcock chicken spit.		GSV1375 Raised rack for meat storage.		PID1375 Stainless steel tray to unspit.	

Front view

Rotisserie with roof (optional) and base on casters (optional)

Side view

Rotisserie with roof (optional) and base on casters (optional)

Top view

Rotisserie with roof (optional) and base on casters (optional)

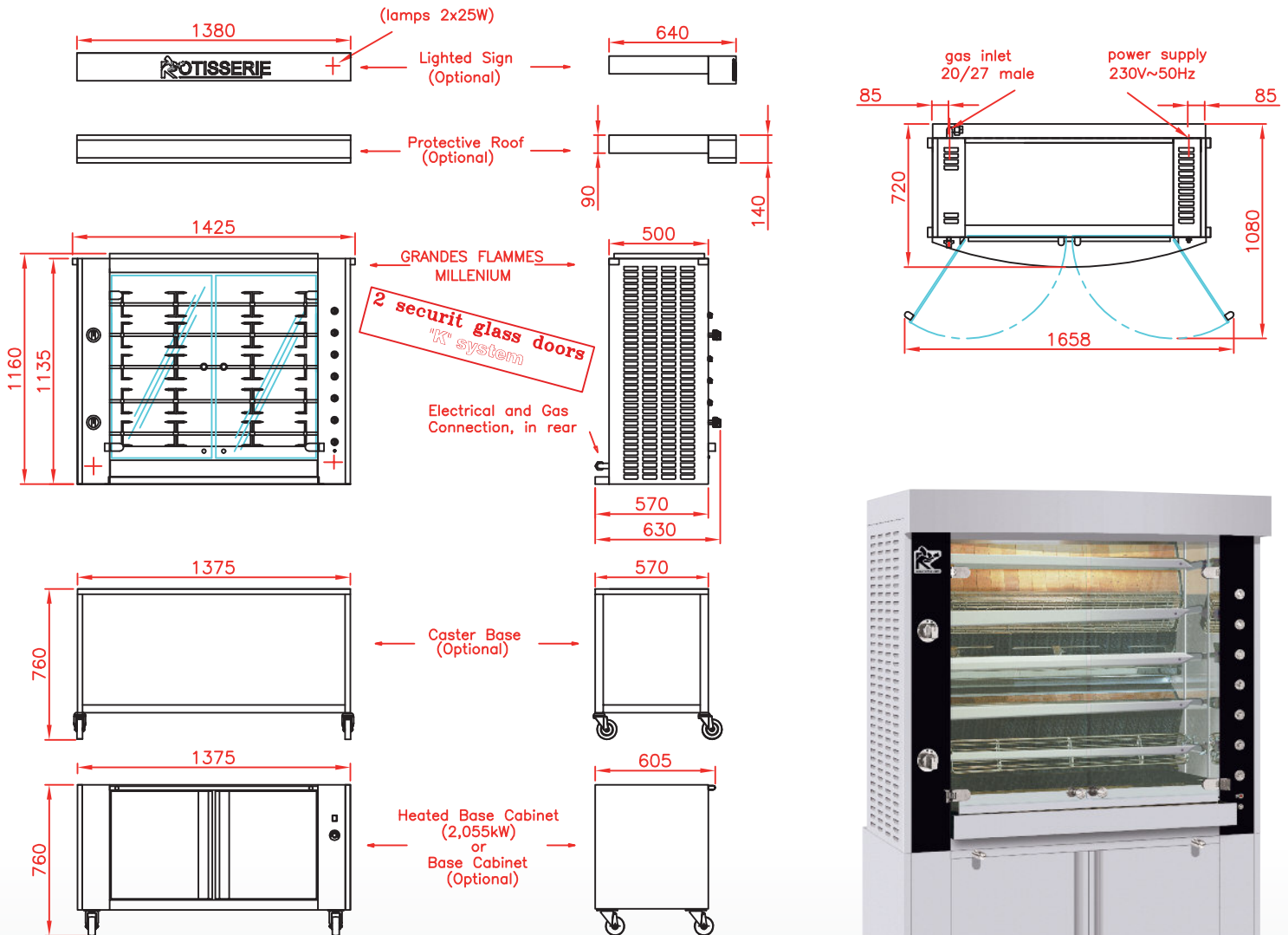

1375.5MSG

Stainless steel finish



SPECIFICATIONS

Gas Power	NG 44kW / LPG 42kW
Gas consumption	Natural Gas 158.4 Mj/hr LPG 151.2 Mj/hr
Gas connection	20/27 male
Electricity	230 V 50 Hz + earth 0.6 kW
Capacity	25/30 chickens (depending on size)
Warranty	1 year on parts (excluding glass doors)
Extraction	Compulsory
Minimum clearance	16 cm on the left and right, 5 cm at the rear
Weight	190 kg without packing

Revised : June 2014

AUSTRALIA DISTRIBUTOR

Rotisol S.A.S.

Zone industrielle La Trentaine, Avenue Gustave Eiffel
77507 Chelles cedex - FRANCE

bennell@rotisol.com - Tel : +33 1 64 21 80 00

www.rotisol.com



CREATIVE
COMMERCIAL

PO Box 83 - Oxenford QLD 4210 - AUSTRALIA

+61 (07) 3218 2111 - info@creative-commercial.com.au