

# MILLENNIUM

## 1375.2MLG/MSG + i

### DESIGN

The MILLENIUM range of attractive ergonomically-designed rotisseries, boasts a number of innovative features for increased functionality and are an ideal show-piece used throughout the world in hotels, restaurants and deli stores.

The naked flame from Rotisol's patented burners lick the cast iron hearth creating a spectacular visual, whilst being safe and simple to operate and easy to clean. Spits are driven by individual motors rotating at 2 ½ times per minute allowing meat or poultry to constantly baste itself, sealing in natural juices and cooking to perfection.

### FEATURES

- ❑ Energy Efficient
- ❑ Independent motors
- ❑ 2 tempered glass doors
- ❑ Safety with installed thermocouple
- ❑ Equipped with bottom drip tray with drainage tap
- ❑ Powerful halogen lamp.

### FINISHES

Standard model in black enamel. A choice of other colours are available. Choses a colour scheme for Millenium.





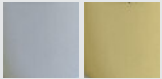





With chrome or brass trims.

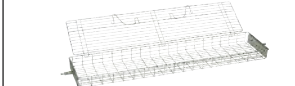

### ACCESSORIES

A variety of accessories are available for the unit. Video of available [accessories](#) and video of [vertical spit system](#).

<b>CUI1375</b> Anti-cutting prongless spit.		<b>BP1375</b> Chicken spit.		<b>BRC1375</b> Basket spit.	
<b>BS1375</b> Sabre spit for ham / turkey.		<b>BRRO1375</b> Roast-clamp spit.		<b>BA1375</b> Lamb/suckling- pig spit.	
<b>BCR1375</b> Spatchcock chicken spit.		<b>GSV1375</b> Raised rack for meat storage.		<b>PID1375</b> Stainless steel tray to unspit.	



**1375.2MLG**

Black and brass finish



### Front view

Rotisserie with roof (optional) and base on casters (optional)

### Side view

Rotisserie with roof (optional) and base on casters (optional)

### Top view

Rotisserie with roof (optional) and base on casters (optional)

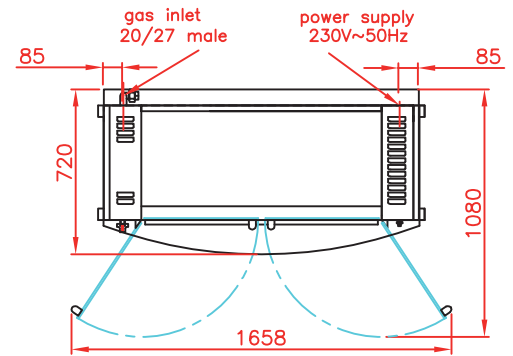
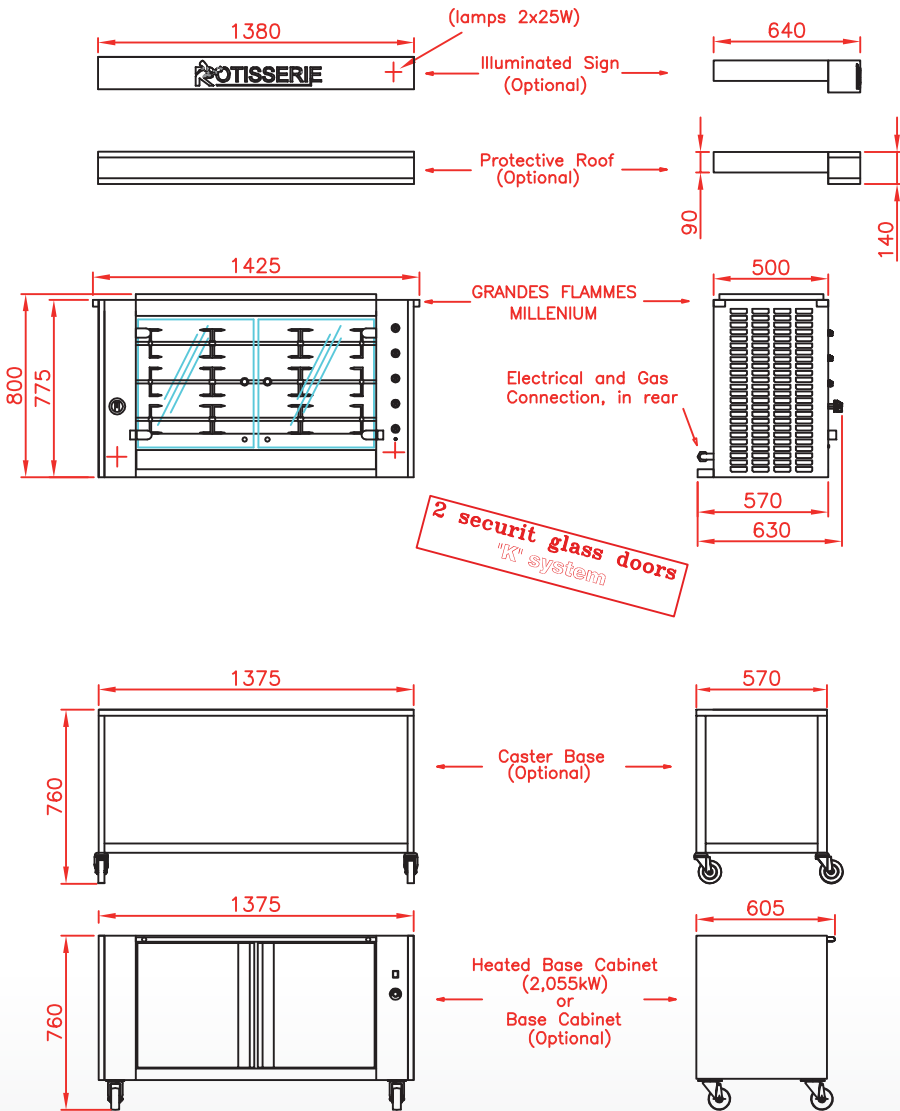

**1375.2MSG**

Stainless steel finish



## SPECIFICATIONS

<b>Gas Power</b>	NG 22kW / LPG 21kW
<b>Gas consumption</b>	Natural Gas 79.2 Mj/hr LPG 75.6 Mj/hr
<b>Gas connection</b>	20/27 male
<b>Electricity</b>	230 V 50 Hz + earth 0.54 kW
<b>Capacity</b>	10/12 chickens (depending on size)
<b>Warranty</b>	1 year on parts (excluding glass doors)
<b>Extraction</b>	Compulsory
<b>Minimum clearance</b>	16 cm on the left and right, 5 cm at the rear
<b>Weight</b>	100 kg without packing

Revised : June 2014

AUSTRALIA DISTRIBUTOR

### Rotisol S.A.S.

Zone industrielle La Trentaine, Avenue Gustave Eiffel  
77507 Chelles cedex - FRANCE

[bennell@rotisol.com](mailto:bennell@rotisol.com) - Tel : +33 1 64 21 80 00

[www.rotisol.com](http://www.rotisol.com)



**CREATIVE**  
COMMERCIAL

PO Box 83 - Oxenford QLD 4210 - AUSTRALIA

+61 (07) 3218 2111 - [info@creative-commercial.com.au](mailto:info@creative-commercial.com.au)