

1. PRESENTATION OF THE APPLIANCE

1.1. GENERAL

Rotisseries range "Spécial marché" using gas and electricity at a voltage of 230V + earth.

Reference rotisserie	Lenght (mm)	Depth (mm)	Height (mm)	Weigth (kg)	Gas power (kw)	Electric power (kw)
1655.8SMG	1655	670	1665	300	52,8	0,76
1655.6SMG	1655	540	1285	235	39,6	0,72
1425.8SMG	1425	670	1665	225	44	0,46
1425.6SMAG	1425	670	1665	210	33	0,42
1425.6SMG	1425	540	1285	170	33	0,42
1425.4SMAG	1425	600	1285	170	22	0,38
1425.4SMG	1425	540	930	130	22	0,38
1175.8SMG	1175	600	1665	180	30	0,46
1175.6SMAG	1175	600	1665	170	22,5	0,42
1175.6SMG	1175	540	1285	135	22,5	0,42
1175.4SMAG	1175	600	1285	125	15	0,38
1175.4SMG	1175	540	930	90	15	0,38
1100.8SMG	1100	590	1640	180	30	0,2
1100.6SMG	1100	490	1260	135	22,5	0,16
1100.4SMG	1100	490	905	90	15	0,08

The unit is for professional use and must be used by a professional person.

Before starting any operation, please see these instructions. The carefully kept available near the rotisserie

While cooking appliance generates heat and particles of fat.

It is advisable to provide for their installation in premises protected anti-fire and ventilated mechanically accordance with safety regulations and health standards relating to trades mouths (please check with specialized companies and agreed on the benefits of work to be done according to safety standards: ventilation (extraction), plumbing (water, gas protection, fire, etc. ...), electricity, building (anti-slip tiles, firewall, etc. ...).

We advise you to hire a qualified dealer for connection and start of the roasting pan as long as reservations are electric and gas conducted by certified companies, authorized by you, and hold near the location of the cooking appliance.

Interventions on electrical parts must be performed by qualified personnel in the compliance with regulations in force

The company is not liable for damages in case of:

- incorrect use of the device
- non-compliance with regulations in force
- proper installation
- non-compliance with the details regarding the maintenance
- Any unauthorized changes
- installation of spare parts unoriginal
- installing and using the rotisserie different than those provided by the manufacturer

The manufacturer's plate is located on the bottom left of the appliance.

1.2. MAKE, MODEL, REFERENCE

Rotisserie **ROTISOL**, model « **Spécial Marché** », reference:

1655.8SMG, 1655.6SMG, 1425.8SMG, 1425.6SMAG, 1425.6SMG, 1425.4SMAG, 1425.4SMG, 1175.8SMG, 1175.6SMAG, 1175.6SMG, 1175.4SMAG, 1175.4SMG, 1100.8SMG, 1100.6SMG and 1100.4SMG

1.2.1. ROTISSERIE SPECIAL MARCHE 1425.6SMAG

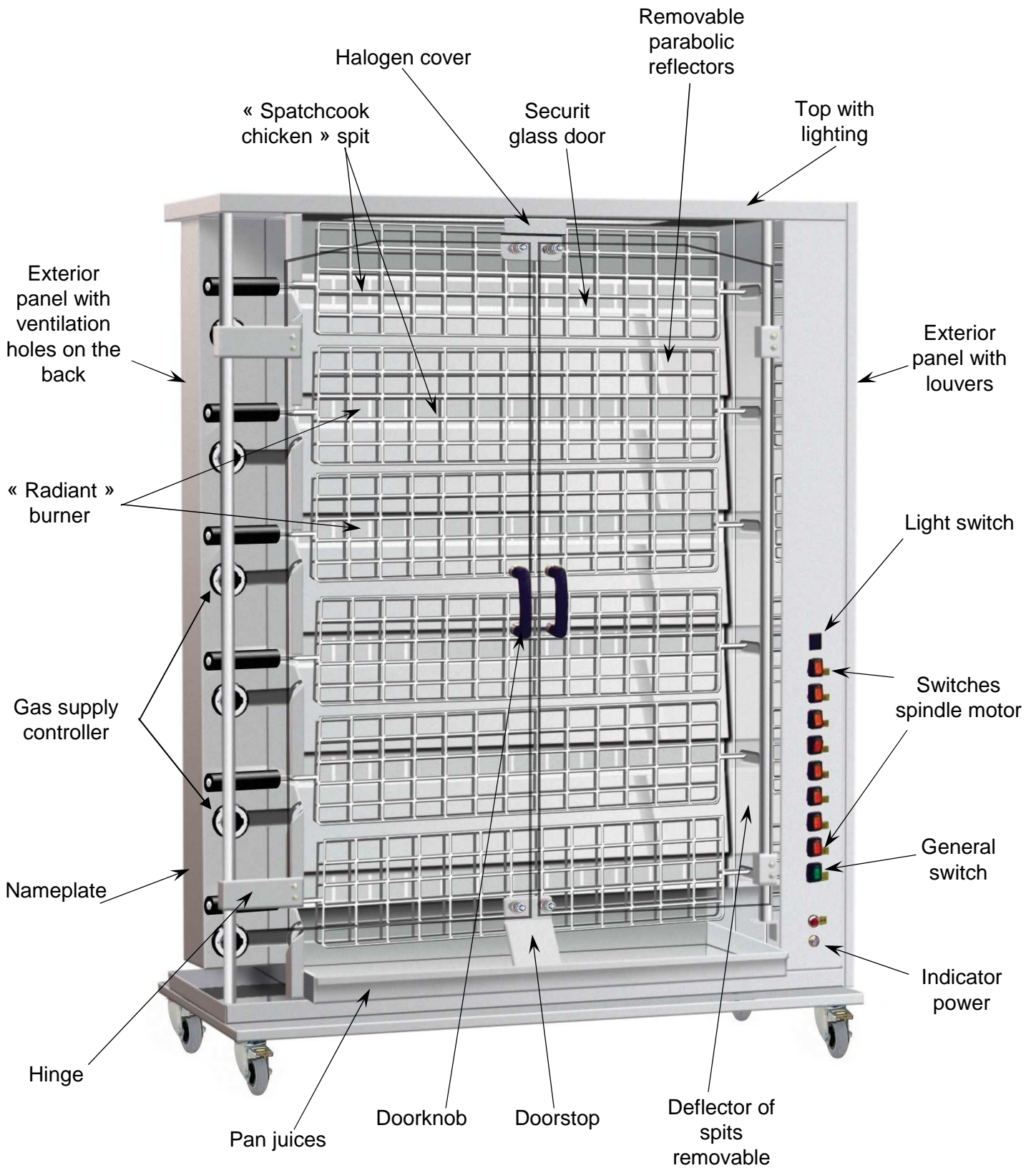

1.2.2. DESIGN

- All stainless steel.
- 8, 6, or 4 spits can be used in 3 different positions , except 1100.8SMG, 1100.6SMG, and 1100.4SMG which are not adjustable .
- Height between the spits 188 mm for models 1655.8SMG, 1655.6SMG, 1425.8SMG, 1425.6SMG, 1425.4SMG, 1175.8SMG, 1175.6SMG, 1175.4SMG, 1100.8SMG, 1100.6SMG and 1100.4SMG.
- Height between the spits 255 mm for models 1425.6SMAG, 1425.4SMAG, 1175.6SMAG et 1175.4SMAG.
- 1 individual motor floating adjustable depth for each spit. equipped with a continuous training Alternative models 1425.6SMAG, 1425.4SMAG, and 1175.6SMAG 1175.4SMAG: rotation "continuous" traditional cooking whole chickens, rotation "alternative" for cooking poultry in open say"center plate" (spindle stop for 20 seconds in a vertical position)
- Deflector protective removable motor on the amount left for cleaning.
- "Radiant" burners operating individually composed of ceramic plate .
- Gas safety by thermocouple.
- Gas supply valve with 2-heating settings.
- Removable parabolic reflectors.
- Securit glass doors with locking in position of opening and closing.
- Pan juices .
- Exterior panels with ventilation openings.
- Removable deflector with ventilation openings on the top for venting and burning fat .

1.3. ACCESSORIES – OPTIONS

- Flexible connection Tubogaz 36/123 - 20/27 .
- Quick Connect NNFD 36/124 .
- Various spits (prongless « V » spits, « spatchcock chicken » spits, poultry spits, etc...).
- Spit mover, gas lighter.
- Grid elevated for storage of meat into pan juices.

1.4. BASE ON CASTERS - OPTIONS

- base with 4 swivel casters, 2 with brakes .
- Top banner decorative enamel , band of red enamel front .
- Internal illumination by halogen lamp .
- Motors of 24 Volts
- Timer

2. COMMISSIONING - USE

2.1. RECOMMENDATIONS FOR USE

- The unit should not be installed close to the steam, grease (fryer, ...), projections water, high temperatures or other adverse condition.
- The pan should be used by qualified personnel.
- Put water in the pan juices to about 1.5 cm. **There must always have water in the tray.**
- In the case of using a pan juices through, it is also imperative to put water in the pan juices to about 1.5 cm. **There must always have water in the tray .**
- The rotisserie should be used by qualified personnel .
- It is essential to keep the glass doors closed to prevent grease splashes, and for the correct operation of the appliance.
- Start your burner "radiant" 15 minutes before cooking so that ceramics are red.
- It is recommended to bring gloves, an apron and a cap for the use of the rotisserie.
- Slide your chickens on the spits and put them in position inside the rotisserie.
- The maximum load of a spit must not exceed is :
8 Kg for the rôtisserie 1175.8SMG, 1175.6SMAG, 1175.6SMG, 1175.4SMAG, 1175.4SMG, 1100.8SMG, 1100.6SMG and 1100.4SMG.
12 Kg for the rôtisserie 1425.8SMG, 1425.6SMAG, 1425.6SMG, 1425.4SMAG and 1425.4SMG
14 Kg for the rôtisserie 1655.8SMG et 1655.6SMG



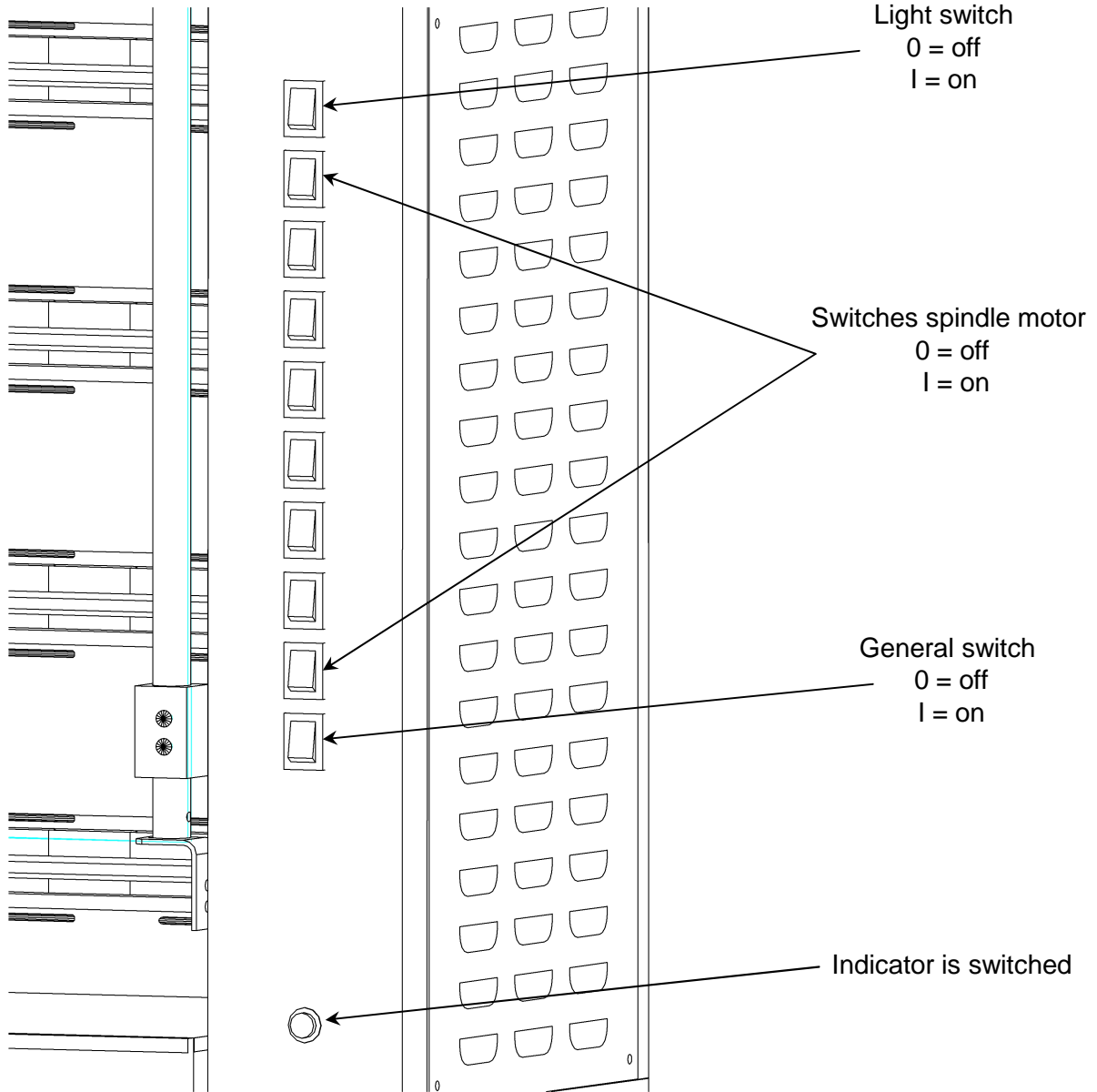

2.1.1. FUNCTIONS OF THE CONTROLS



2.1.2. OPERATING INSTRUCTIONS

1. Check the electrical connection of the rotisserie with the mains.
2. Check the gas connection (gas tap).
3. Check if the machine is powered up, white indicator lit .
4. Turn the general switch to position "1" (see previous page).
5. Turn the light switch to position "1" to illuminate the inside of the rotisserie (see previous page).
6. Light the "radiants" burners (see 2.1.3. below).
7. To start the rotation of one spit, turn the corresponding switch to position "1" .
(see previous page)
8. To stop the spit rotating, turn the corresponding switch to position "0" .
9. Turn the light switch to position "0" to turn off the light in the rotisserie
10. Turn the general switch to position "0" to turn off the rotisserie
11. Close the gas stop valve.

2.1.3. IGNITION OF THE BURNERS

- Open the gas shut-off valve
- Turn the burner knob to the left to use: symbol «» to the tap or 22S «» symbol to the tap to the 20S marker «0» and press it (Figure 2).
While holding the lever pressed, move the flame (torch lighter) under the thermocouple for 5 to 10 seconds (longer during the first use to purge air from the pipe).
- Turn the knob to the left position heaters maximum «» (figure 3).
- Turn possibly the knob in position of minimum heat «» (figure 4).
- To turn of the radiant burner, put the knob in pilot position «0» (figure 1).

ROBINET 20S

ROBINET 22S

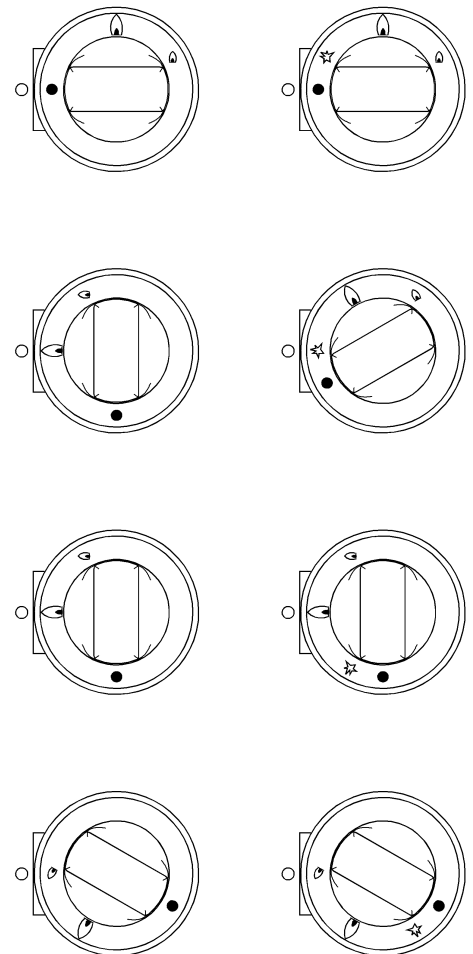

2.2. RECOMMENDATIONS

2.2.1. WHAT YOU SHOULD DO

- *Always put water in the pan juices to about 1.5 cm .*
- *Use gloves resistant to heat for to load and unload pin of chicken of the rotisserie.*
- *Clean the burners regularly .*
- *The flow of combustion and ventilation air must be easy and unobstructed .*
- *Clean the glass doors, deflectors and interior panels every day with a mild detergent.*
- *Glass doors with protection against heat are expensive, do not forget to ensure them (they are not guaranteed).*

2.2.2. WHAT NOT TO DO

- *Never overwhelmed grease drip tray . Emptied regularly. The grease could ignite*
- *Never use a tray drip with a burner lit below. The temperature is too high and the fat could catch fire.Place it below the first burner lit at a safe distance.*
- *Do not touch lamp "HALOGEN" with your fingers.*
- *Do not handle the adjustment screws of the reduced flow and slowed down (see instructionsparagraphescorrespondants installers) these adjustments have been made and sealed once and for all in the factory)*
- *Never leave combustible material within 70 centimeters from the front panel.*

2.3. COUNCIL COOKING

- The cooking time varies depending on the size of your chicken in between 45 to 60 minutes.
- You can, after baking, let turn your pin chicken, provided to turn off the burners.
- You can adjust the distance of your chicken spit relative to the burners with dropouts, this, same glass doors closed.

3. CLEANING - MAINTENANCE

Caution: Do not use a jet or a bucket of water to clean the rotisserie

3.1. DAILY

It is very important that your rotisserie is cleaned after each use. Soak spindles, spindle peaks and tray drip for easier cleaning.

External glazed panels should be cleaned with a non-abrasive detergent (see MEGACLEAN VITRES).

3.2. EVERY MONTH

Clean burners

3.3. EVERY 4 MONTHS

Using a brush apply the MEGACLEAN PIN on the spindle drive side engine right in your rotisserie The run for 15 to 20 minutes and rinse lightly with clear water and wipe dry.

3.4. EVERY 6 MONTHS

Verify and monitor the cleanliness of all INJECTOR / VENTURI.

Lubricate the drive motors

FOR A BETTER SERVICE, YOU ARE ADVISED AN INTERVIEW TIME TO BE PERFORMED BY A QUALIFIED INSTALLER.

3.5. PIECES NEED TO BE REPLACED POSSIBLE

Glaces, halogen lamps, switches, pilot lights, thermocouples and motors can be replaced during the lifetime of the device.

4. CHECKING OF THE GOODS

The product travels at the risk of the buyer. He should check the good condition.

On receiving the goods, one should proceed as follows:

Check in the presence of the driver deliveryman, and quantity of the goods. If there are any abnormalities call your insurance company to make a claim or make a claim directly with the transport company.

5. GARANTIE

Rotisol guarantee for a period of 12 months from the invoice date to the specification by Rotisol manufacturing.

In case of manufacturing defect, the procedure for exchange or repair of products recognized as defective.

The exchange of parts under warranty requires the buyer to provide a copy of the original invoice of the goods.

The cost and risks of transportation, the cost of dismantling, reassembling, spare parts and repair costs on site (staff, accommodation and equipment) are the responsibility of the buyer.

The warranty does not cover defects that come from the non-compliance of the installation, the product (improper installation, connection error, overvoltage, lightning, ect...), and incorrectly used modification or intervention by the purchaser or a third party.

Are excluded from the benefit of the guarantee the following items: mirrors, glass, quartz halogen lamps, granite, light bulbs, gaskets. We advise our clients to take out insurance « broken windows ».

To obtain warranty, all defective parts must be returned to 8 days. The parts under warranty are sent out at costs to the customer and are reimbursed upon receipt of defective parts, after inspection in our workshops.

Products replaced under warranty are guaranteed themselves for the remaining term to run under the original warranty.

Past 12 month warranty, all new parts replaced or shipped, pay the postage or labor force and displacement and will be guaranteed three months from the date of invoice.

In case of dispute the customer will be required to provide the original invoice, the absence of this document will void the warranty.

Any technical assistance from Rotisol will be bill to the customer.

COOKING TIME

PRODUCTS	Cooking time	Temperature In °C
CHICKEN 1.3 KG 1.5 KG	1H	220°
Sparerib's 250 G cooked	30mn	220°
Mice lamb cooked	30mn	220°
knuckle's 600 G cooked	45mn	220°
Jarreton cooked	45mn	220°
Roast pork cooked	45mn	220°
Cooked pork	45mn	220°
Spareribs cooked	45mn	220°
Brisket cooked	1H	220°
Boiled knuckle	45mn	220°
Ham cooked on a spit	45mn	220°
Preheating	15mn	220°

ROTISO(ASIA)LTD.

G/F 68, Po Hing Fung, Sheung Wan HONK KONG
 Tel : (852) 2984 9867 - Fax : (852) 2984 8543
 E-mail: sam@rotisol.com.hk www.rotisol.com.hk

ROTISOL-EST Sp-z o.o.

ul. Przemysłowa 7c 11-700 MRAGOWO POLAND
 Tel. / fax : 0048 89 741 32 70 - Tel. : 0048 89 741 16 05
 Tel. kom : 0048 0603 634 927
 E-mail: info@rotisol.com.pl www.rotisol.pl

ROTISOL France, Inc

341 North Oak Street - INGLEWOOD, CA90302-USA
 Toll free: 800 651 5969 Tél: (310) 671 7254 Fax: (310) 671 8171
 E-mail: info@rotisolusa.com www.rotisolusa.com

ENTRANCE MAP

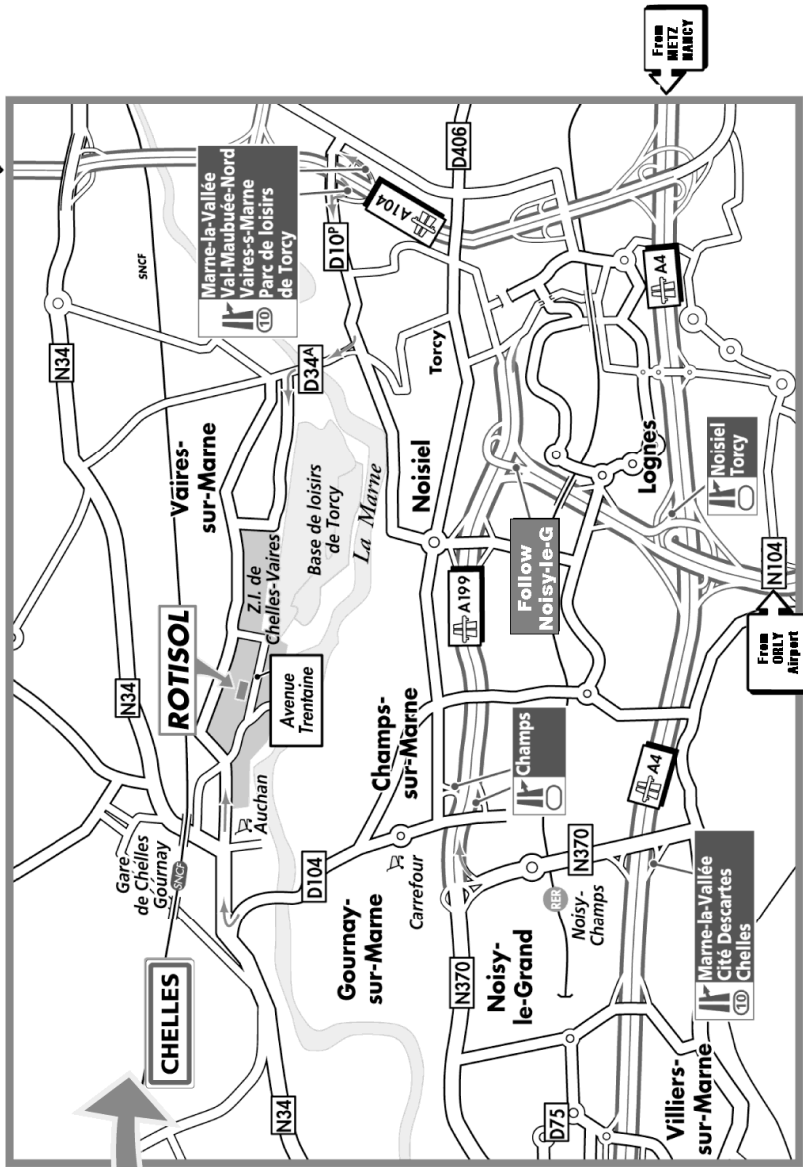
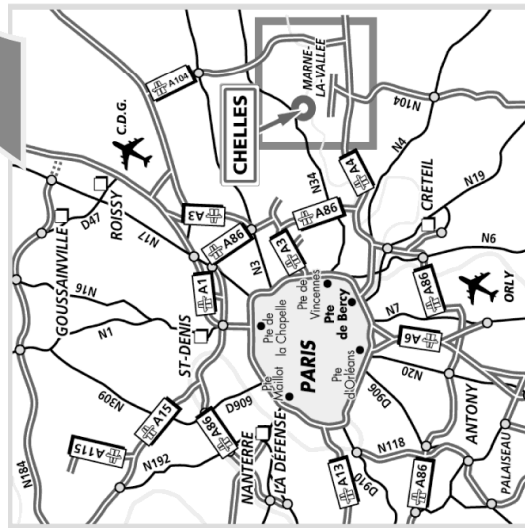

From Paris : join Porte de Bercy (Bercy gate), then motorway A4, direction Marne-la-Vallée / Metz / Nancy.
 Take the exit n° 10 Marne-la-Vallée / Cité Descartes / Chelles. Follow the N370 then on motorway A199,
 direction Champs-sur-Marne / Chelles. Take the first exit Champs (and follow the map).
 Or : from Porte de Vincennes (Vincennes gate), follow the N34, direction Chelles (and follow the map).
 Or : from Paris, take motorway A4 direction Marne-la-Vallée / Metz / Nancy, then follow la Francilienne
 A104 direction Marne-la-Vallée / Aéroport CDG / Lille. Take exit n° 10 Marne-la-Vallée / Val Maubuée
 Nord / Vaires-sur-Marne / Parc de Loisirs Torcy (and follow the map).
 From Orly Airport : join the N7, direction Créteil to take motorway A86 direction Marne-la-Vallée.
 Then take motorway A4 direction Metz / Nancy and follow A104 La Francilienne, direction
 Marne-la-Vallée / Aéroport CDG / Lille. Take the exit n° 10 Marne-la-Vallée / Val Maubuée Nord / Vaires-
 sur-Marne / Parc de Loisirs Torcy (and follow the map).

From Charles-de-Gaulle (CDG) Airport : join motorway A1, direction Paris, then follow
 A104 la Francilienne, direction Marne-la-Vallée. Take exit n° 10 Marne-la-Vallée/ Val Maubuée Nord /
 Vaires-sur-Marne / Parc de Loisirs Torcy (and follow the map).
 From Metz / Nancy : join motorway A31 direction Paris, then follow A104 la Francilienne, direction
 Marne-la-Vallée / Val de Lagny / Lagny-sur-Marne. Take the exist n°10 Marne-la-Vallée/ Val Maubuée
 Nord / Vaires-sur-Marne / Parc de Loisirs Torcy (and follow the map).
 From Paris by train : Gare de l'Est station, direction Meaux. Exist at Gare de Chelles / Gournay station
 (30 minutes).
 Depuis Paris by RER : Hausmann / Saint-Lazare station, take RER E4 (EOLE), direction
 Chelles / Gournay. Exist at Chelles / Gournay RER station (20 minutes).

