



SPECIAL-MARKET 1425.4SME/SMiE

DESIGN

The SPECIAL MARKET range of rotisseries have been designed with performance, practicality and mobility in mind. Light weight and compact they are the ideal rotisserie for markets and food trucks and offer a rapid output together with cooking quality.

The electrical heating elements provide an even distribution of heat throughout the unit - enabling fast batch cooking of poultry (1.2 kg) in an hour.

FEATURES

- ❑ Independent motors
- ❑ Spits with Bakelite handles
- ❑ Optional lighting
- ❑ Powerful reinforced electrical heating elements
- ❑ 2 tempered glass doors (removable for transport)
- ❑ Optional personalised removable roof signage
- ❑ Equipped with bottom drip tray with drainage tap

FINISHES

Standard model in finished STAINLESS STEEL. A choice of front coloured panels are available











1425.4SME

Black front panels and stainless steel finish



ACCESSORIES

A variety of accessories are available for the unit. Video of available [accessories](#).

CUI1425 Anti-cutting prongless spit. 	BP1425 Chicken spit. 	BRC1425 Basket spit. 
BS1425 Sabre spit for ham / turkey. 	BRRO1425 Roast-clamp spit. 	BA1425 Lamb/suckling-pig spit. 
BCR1425 Spatchcock chicken spit. 	GSV1425 Raised rack for meat storage. 	DEC Spit mover. 

Front view

Rotisserie with roof (optional) and base on casters (optional)

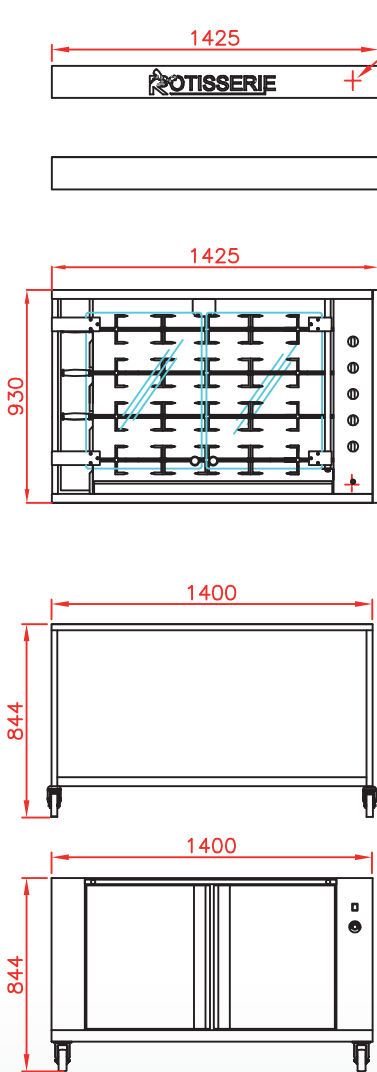

Side view

Rotisserie with roof (optional) and base on casters (optional)

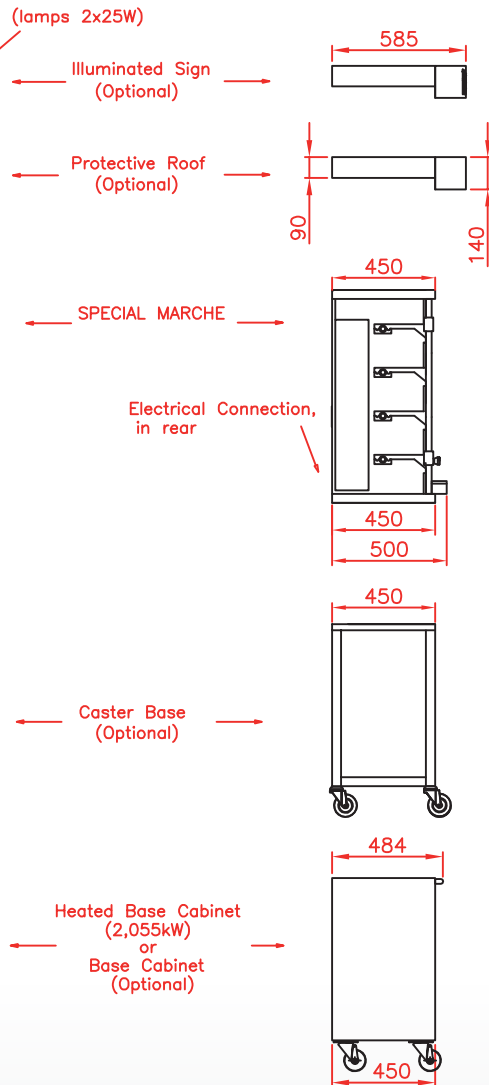

Top view

Rotisserie with roof (optional) and base on casters (optional)

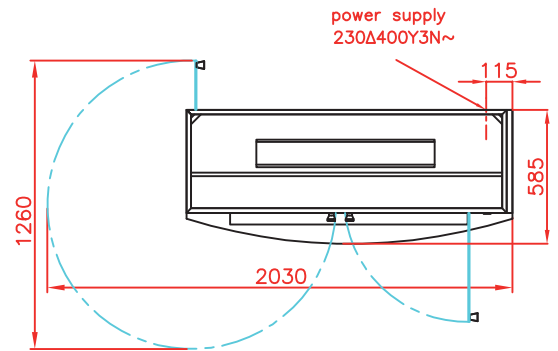

1425.4SMiE

Stainless steel finish



SPECIFICATIONS

Electricity	400 V 3 phases + neutral + earth 20.6 kW
Electrical connection	wire length 2 meters
Capacity	20/24 poultries (depending on size)
Warranty	1 year on parts (excluding glass doors)
Extraction	Compulsory
Minimum clearance	62 cm on the left, 5 cm on the right, 20 cm at the rear
Weight	130 kg without packing

Revised : June 2014

DISTRIBUTOR / AGENT

Rotisol S.A.S.

Zone industrielle La Trentaine, Avenue Gustave Eiffel

77507 Chelles cedex - FRANCE

s.bennell@rotisol.com - Tel : +33 1 64 21 80 00

www.rotisol.com