



SPECIAL-MARKET

1175.6SME/SMiE



DESIGN

The SPECIAL MARKET range of rotisseries have been designed with performance, practicality and mobility in mind. Light weight and compact they are the ideal rotisserie for markets and food trucks and offer a rapid output together with cooking quality.

The electrical heating elements provide an even distribution of heat throughout the unit - enabling fast batch cooking of poultry (1.2 kg) in an hour.

FEATURES

- ❑ Independent motors
- ❑ Spits with Bakelite handles
- ❑ Optional lighting
- ❑ Powerful reinforced electrical heating elements
- ❑ 2 tempered glass doors (removable for transport)
- ❑ Optional personalised removable roof signage
- ❑ Equipped with bottom drip tray with drainage tap

FINISHES

Standard model in finished STAINLESS STEEL. A choice of front coloured panels are available



1175.6SME

Black front panels and stainless steel finish



ACCESSORIES

A variety of accessories are available for the unit. Video of available [accessories](#).

CUI1175 Anti-cutting prongless spit.		BP1175 Chicken spit.		BRC1175 Basket spit.	
BS1175 Sabre spit for ham / turkey.		BRRO1175 Roast-clamp spit.		AT Gas lighter.	
BCR1175 Spatchcock chicken spit.		GSV1175 Raised rack for meat storage.		DEC Spit mover.	

Front view

Rotisserie with roof (optional) and base on casters (optional)

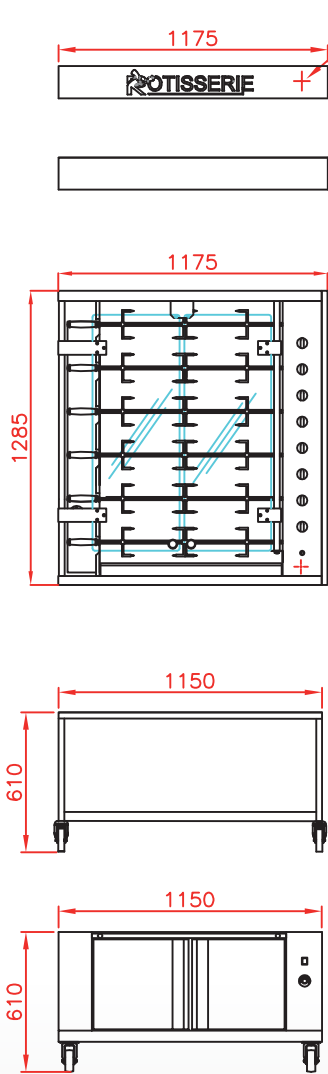

Side view

Rotisserie with roof (optional) and base on casters (optional)

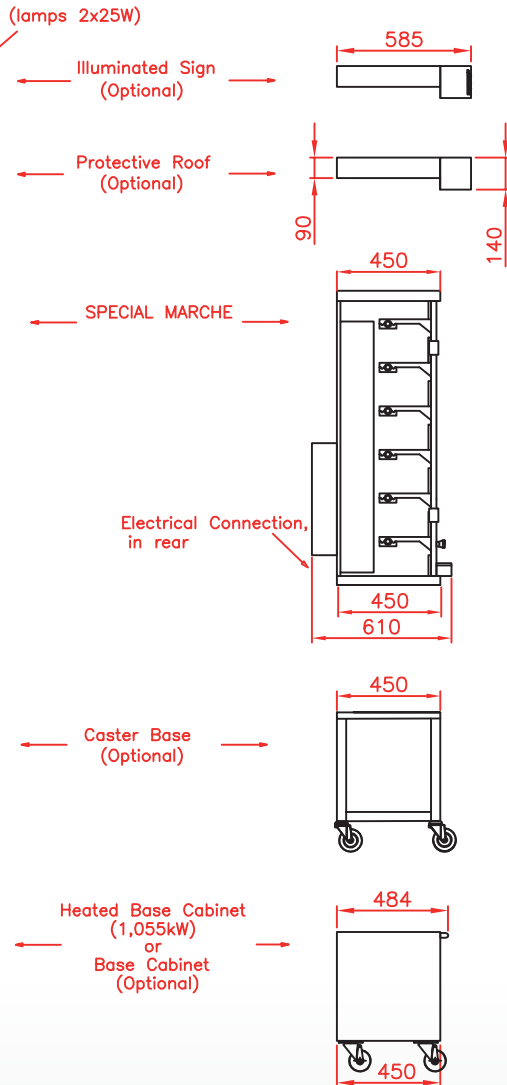

Top view

Rotisserie with roof (optional) and base on casters (optional)

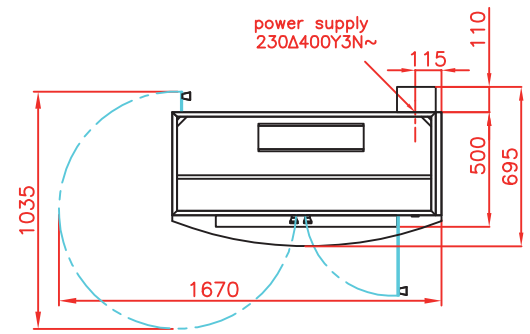

1175.6SMiE

Stainless steel finish



Revised : June 2014

SPECIFICATIONS

Electricity	400 V 3 phases + neutral + earth 19.5 kW
Electrical connection	wire length 2 meters
Capacity	24/30 poultries (depending on size)
Warranty	1 year on parts (excluding glass doors)
Extraction	Compulsory
Minimum clearance	51 cm on the left, 5 cm on the right, 10 cm at the rear
Weight	135 kg without packing

DISTRIBUTOR / AGENT

Rotisol S.A.S.

Zone industrielle La Trentaine, Avenue Gustave Eiffel

77507 Chelles cedex - FRANCE

s.bennell@rotisol.com - Tel : +33 1 64 21 80 00

www.rotisol.com